

Venus Flytrap

This model doesn't really fly, but it might catch a fly if you try folding it out of sticky, smelly paper. But I'm a vegetarian, so I haven't tried.

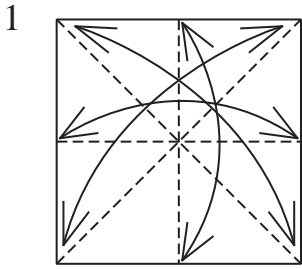

1 White side up, Valley-fold and unfold in half every which way.

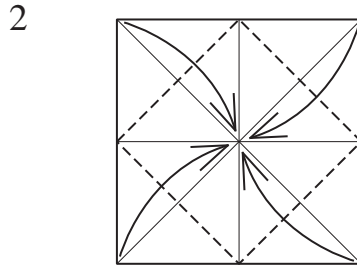

2 Blintz the four corners.

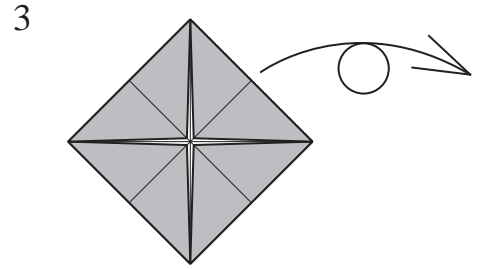

3 Turn the model over.

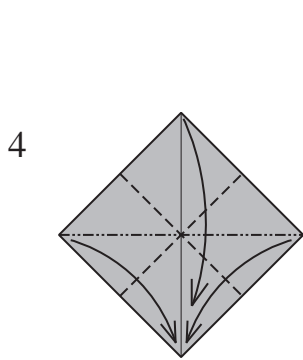

4 Fold a preliminary base.

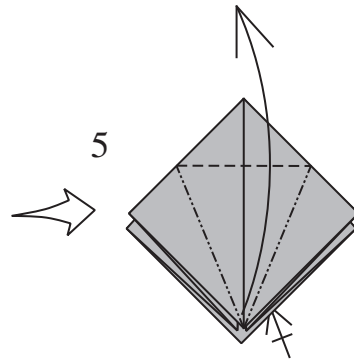

5 Petal fold the front and back flaps to form a bird base.

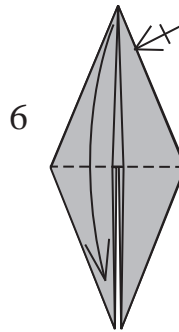

6 Fold the flaps down.

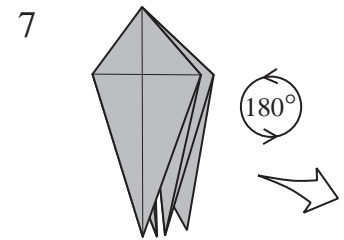

7 Rotate the model 180°.

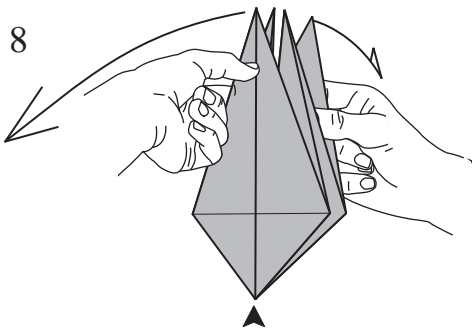

8 Wonder Twin Powers activate... form of a Stretched Bird Base. To do this, hold on to the front and back flaps, and pull them as far apart as possible.

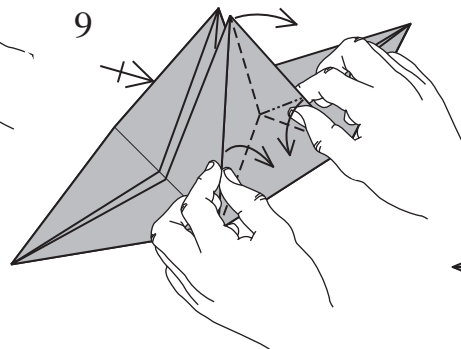

9 Now collapse the central region, and bend the flaps over to one side.

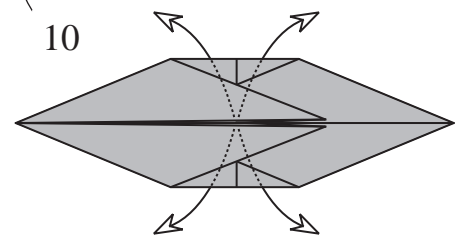

10 The Stretched Bird Base has been activated. Liberate the blintzed corners which are trapped behind the model. Partially unfolding the model makes this liberation easier

11

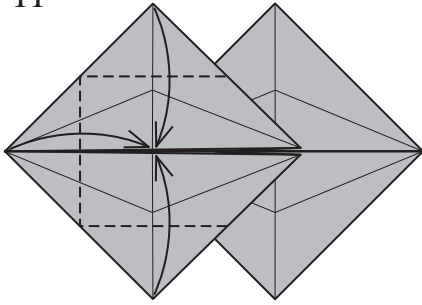

Blintz the left corners.

12

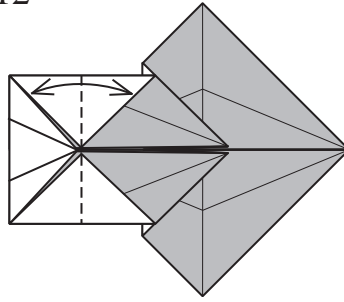

Valley-fold and unfold.

13

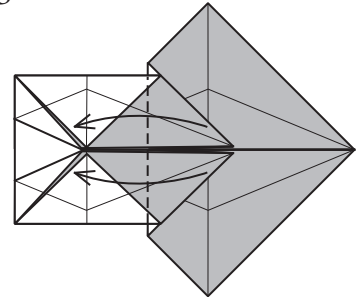

Swing the center flaps to the left.

14

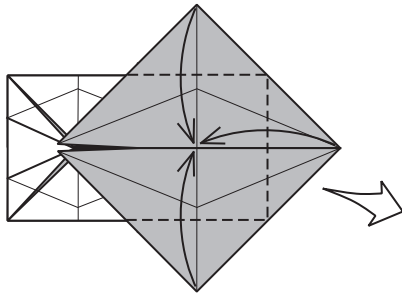

Blintz the right corners.

15

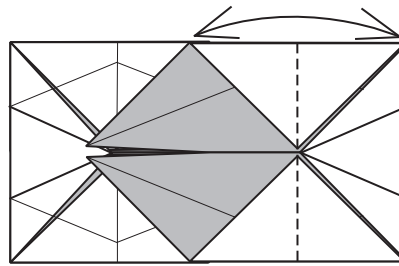

Valley-fold and unfold.

16

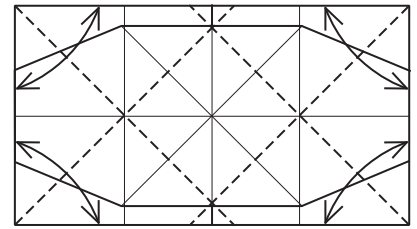

Valley-fold and unfold diagonally through all layers.

17

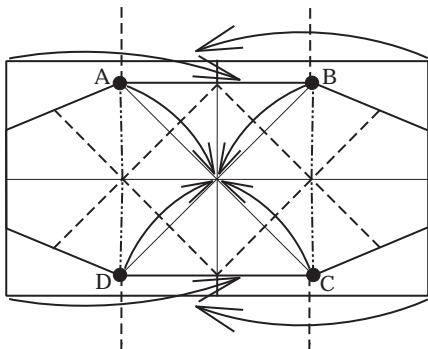

Valley-fold in the left and right sides (they will overlap), while at the same time lifting up and folding points A, B C, and D to the center along existing creases.

18

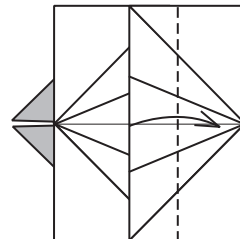

Swing the top flap over as far as it will go, but you needn't crease it -- just get it out of the way so we can see underneath.

19

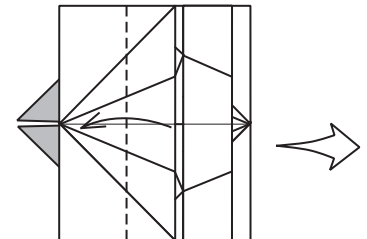

Do the same with this flap.

20

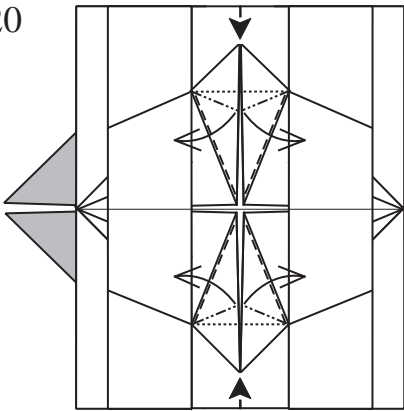

Squash fold.

21

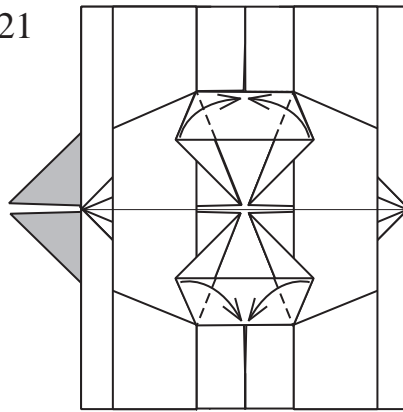

Valley-fold.

22

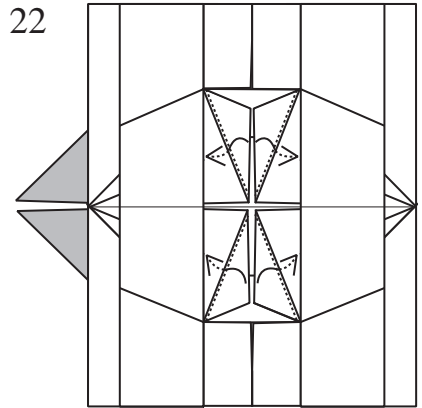

Valley-fold the four flaps, inserting them into the **REAR** pockets.

23

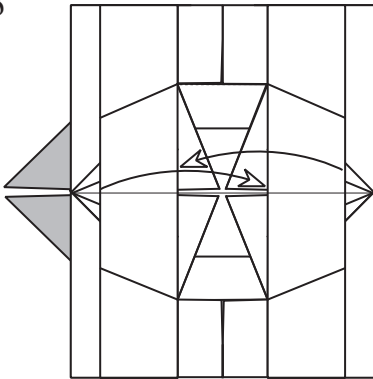

Close back up the two edges to their original positions.

24

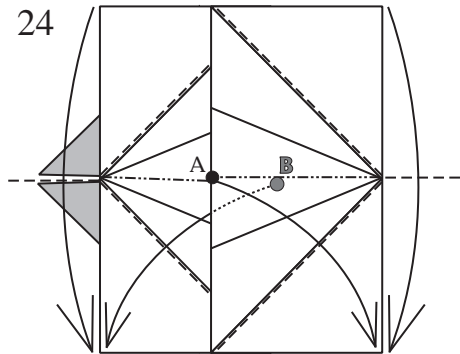

Valley-fold top down to the bottom, while at the same time lifting up and folding out points A , B (similar to step 16).

25

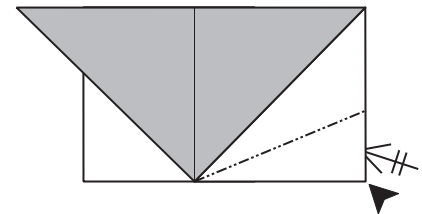

Reverse-fold the three corners.

26

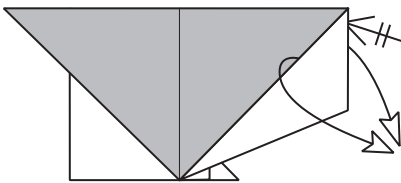

Release the three trapped corners. Unfolding partially makes this easier.

27

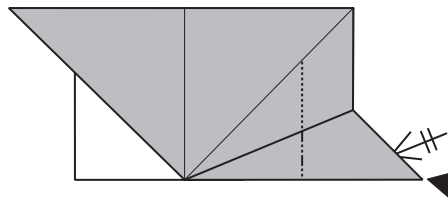

Reverse, reverse, reverse.

28

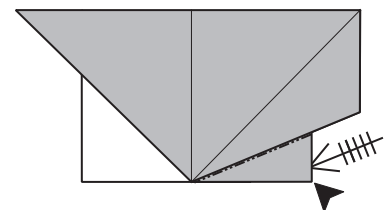

Reverse, reverse, reverse, reverse, reverse, reverse.

29

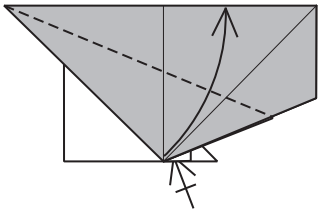

Valley-fold. Repeat behind.

30

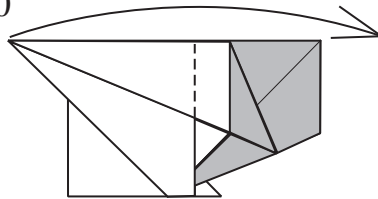

Swing the flap to the right.

31

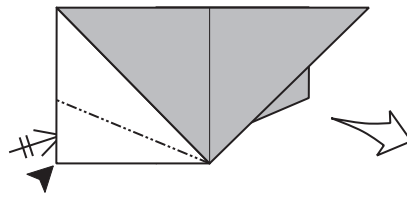

Repeat steps 25-29 on this side.

32

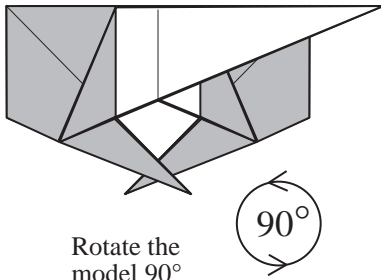

Rotate the model 90°

OPTIONAL

Very Scary Variation

32a

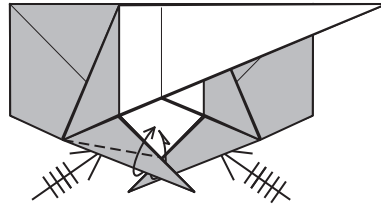

For a less cute, much scarier, more realistic-looking Venus fly trap, try outside reverse-folding the teeth.

32b

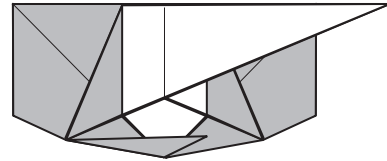

As thus!

33

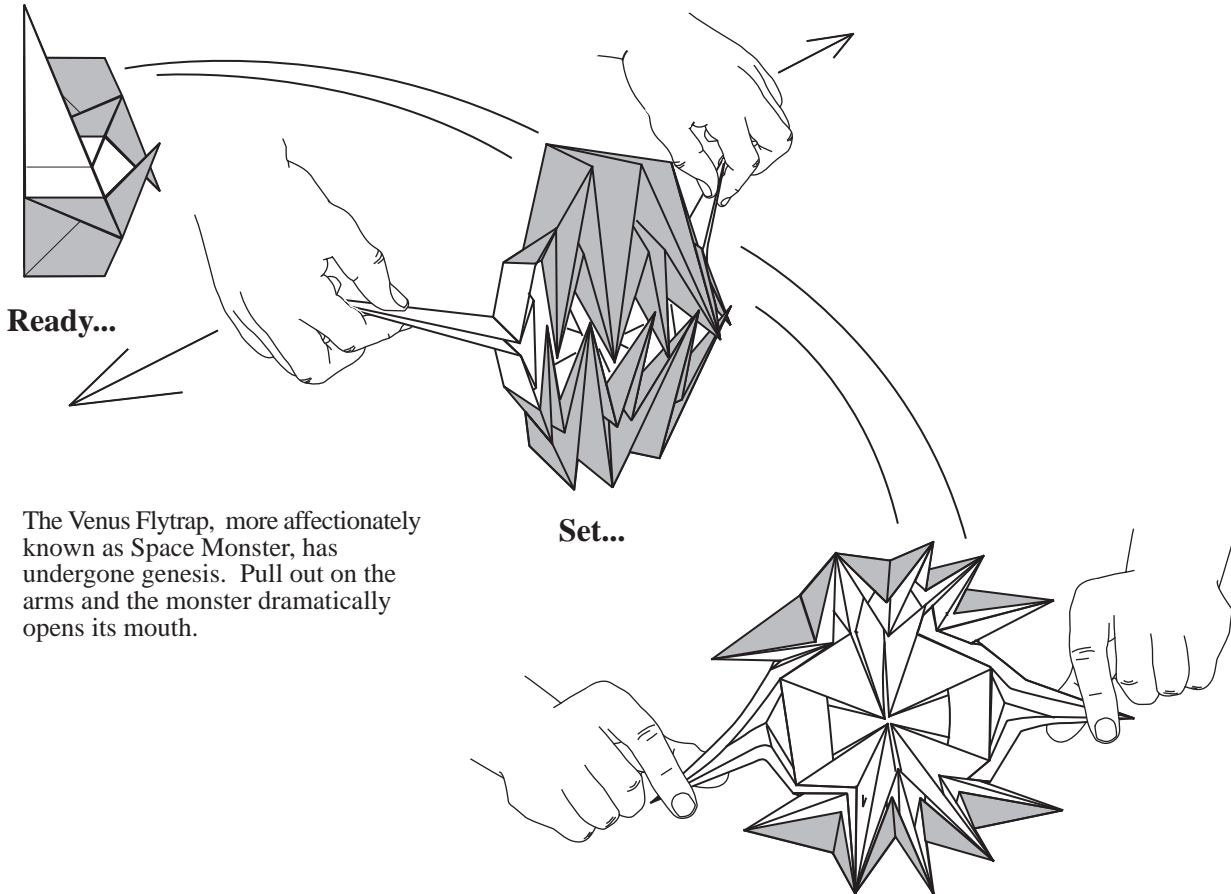

The Venus Flytrap, more affectionately known as Space Monster, has undergone genesis. Pull out on the arms and the monster dramatically opens its mouth.

ATTACK of the Space Monster!